



EDWARDS

TRANS-PORTER

FRONT MOUNT

Series TP8300

SPECIFICATIONS

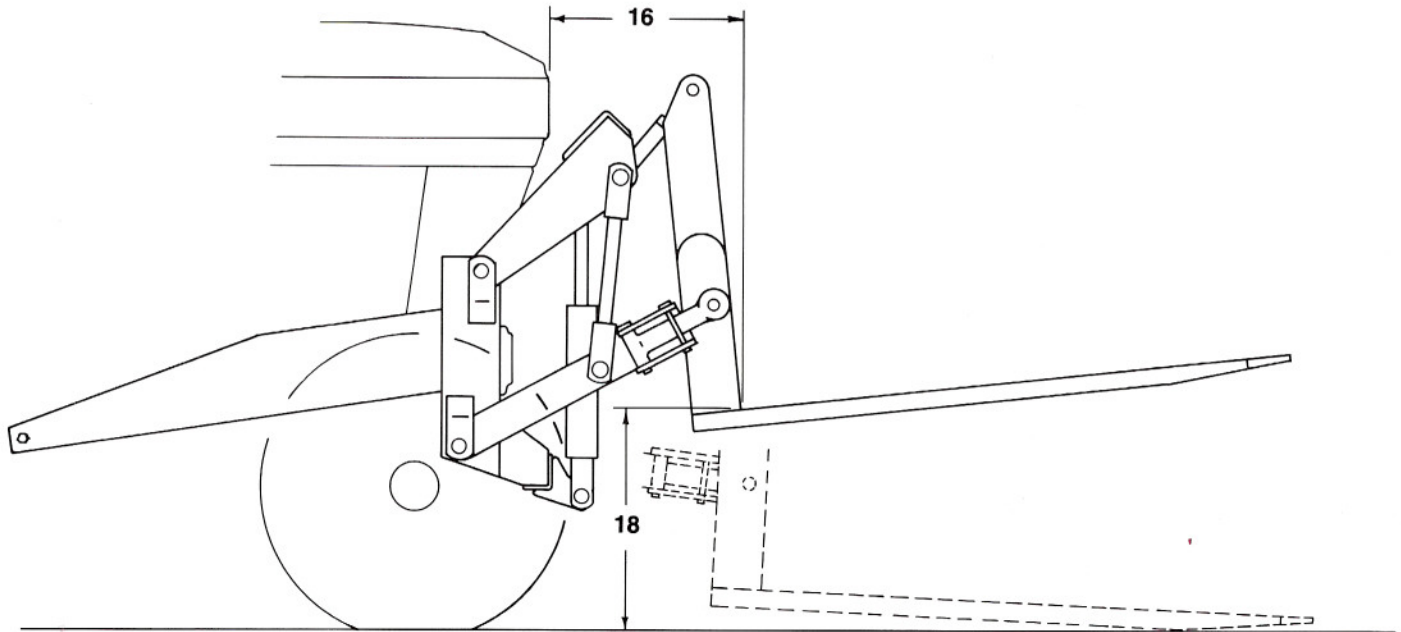

Maximum load at 24 inch load center	1500 pounds
Hydraulic pressure required for maximum load	1500 psi
Ground clearance	10 inches
Degrees tilt forward in lowered position	3
Degrees tilt rearward in raised position	6
Approximate shipping weight	632 pounds
Requires one spool four-way valve or one remote valve for operation.	

* This dimension will be different for each make and model of tractor.
 Specifications and design subject to change without notice.