



TT5100

413.1011a

# UNIVERSAL LIFTS

## THREE POINT FORK LIFTS

The Edwards Universal Lifts are designed for easy-on, easy-off convenience. The Universal Lift can be used for lifting, moving and loading palletized material, bins and other bulky or heavy objects. The time-saving features of the Universal Lift make the investment well worthwhile in itself. The new Edwards Universal Lifts mount quickly and easily on any category 1 or 2 three point hitch tractor. Think of the many labor saving ways you can use a 3 point mounted Edwards Universal Lift.

- Sealed ball bearing support carriage
- Retractable stand holds unit in vertical position for convenient storage and installation
- Hydraulic cylinder top link permits tilting forks forward and backward
- Adjustable top link position to fit variety of tractor hitches.
- Anti friction bearing idler carries heavy chain to support load
- I-Beam Mast with Roller Bearings
- Prop supports top link cylinder for convenient hookup. Orifices in cylinders assure smooth, safe operation
- Removable fork anchors hold forks down for easy pull out from loads
- Optional attachments available
- Specification and design subject to change without notice



Model Number	TT5100
A. Lift Capacity-Pounds at 24 inches	4000
B. Three-Point Lift Height*	24"
C. Reach	6"
Reach with Side Shift	9"
D. Overall Height Mast Lowered	65"
E. Overall Height Mast Raised	89"
F. Maximum Lifting Height	64"
H. Degrees Tilt Forward	6 to 10 degrees
J. Degrees Tilt Rearward	9 to 13 degrees
K. Mast Lifting Height (F-B)	96"
Approximate Shipping Weight	1300 pounds
Three Point Hitch Category	2 or 3
Mast Type	Telescoping
Forks, Heat Treated Alloy Steel	1-1/2 x 5 x 46
Fork Carriage Width	36"

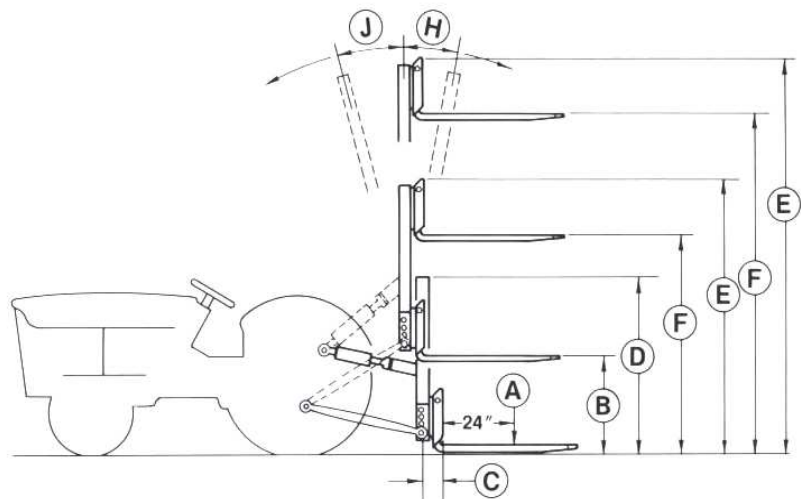

**EDWARDS**  
EQUIPMENT COMPANY

4312 Main Street Union Gap WA 98903

509-248-1770

800-452-5151

Fax: 509-248-9721

Web Site: [www.edwards-equip.com](http://www.edwards-equip.com)

E-mail: [sales@edwards-equip.com](mailto:sales@edwards-equip.com)

Agricultural

MANUFACTURES

industrial